

Plan LGH A  
1 : 50

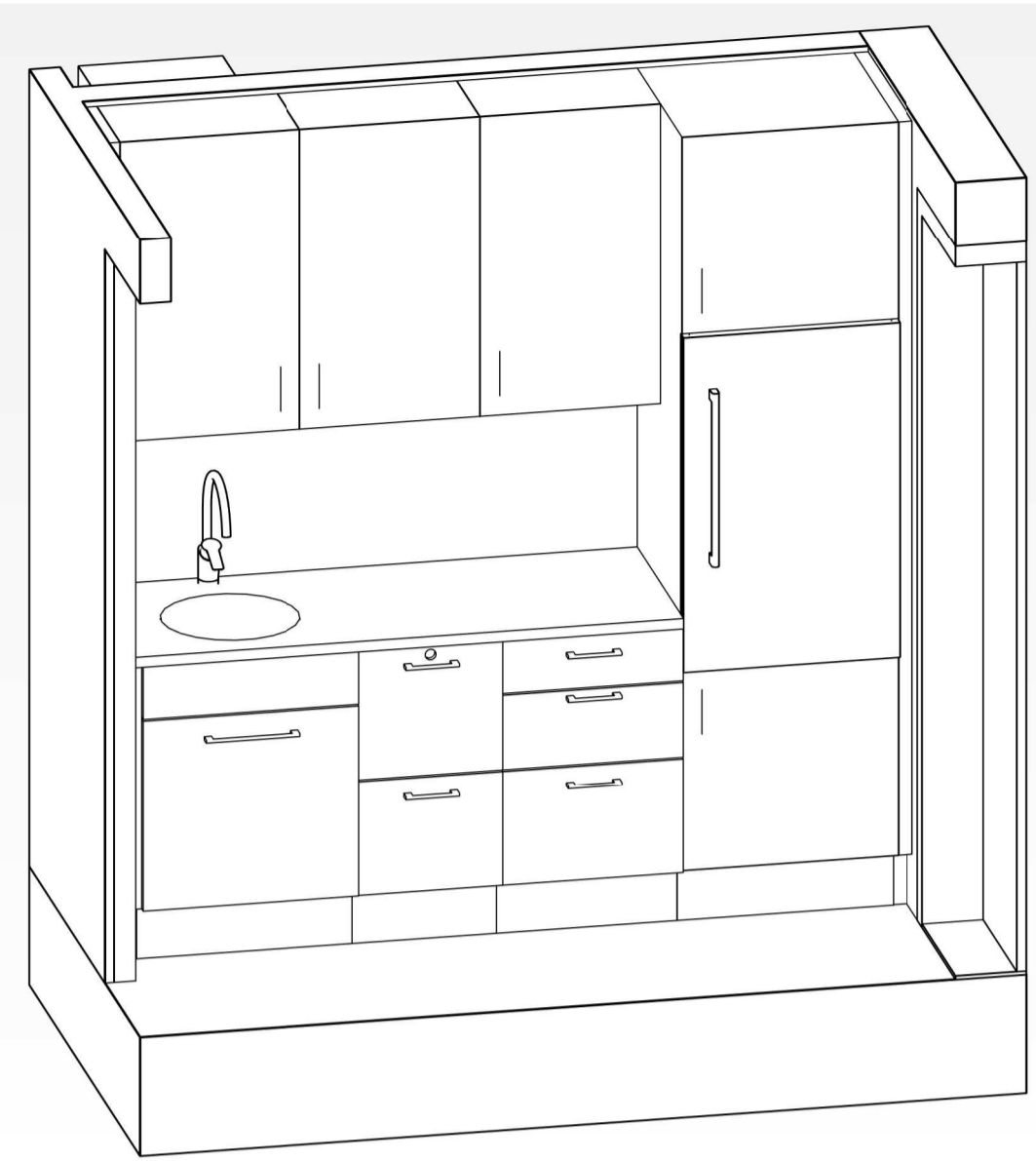

Pentry lgh-3d-1

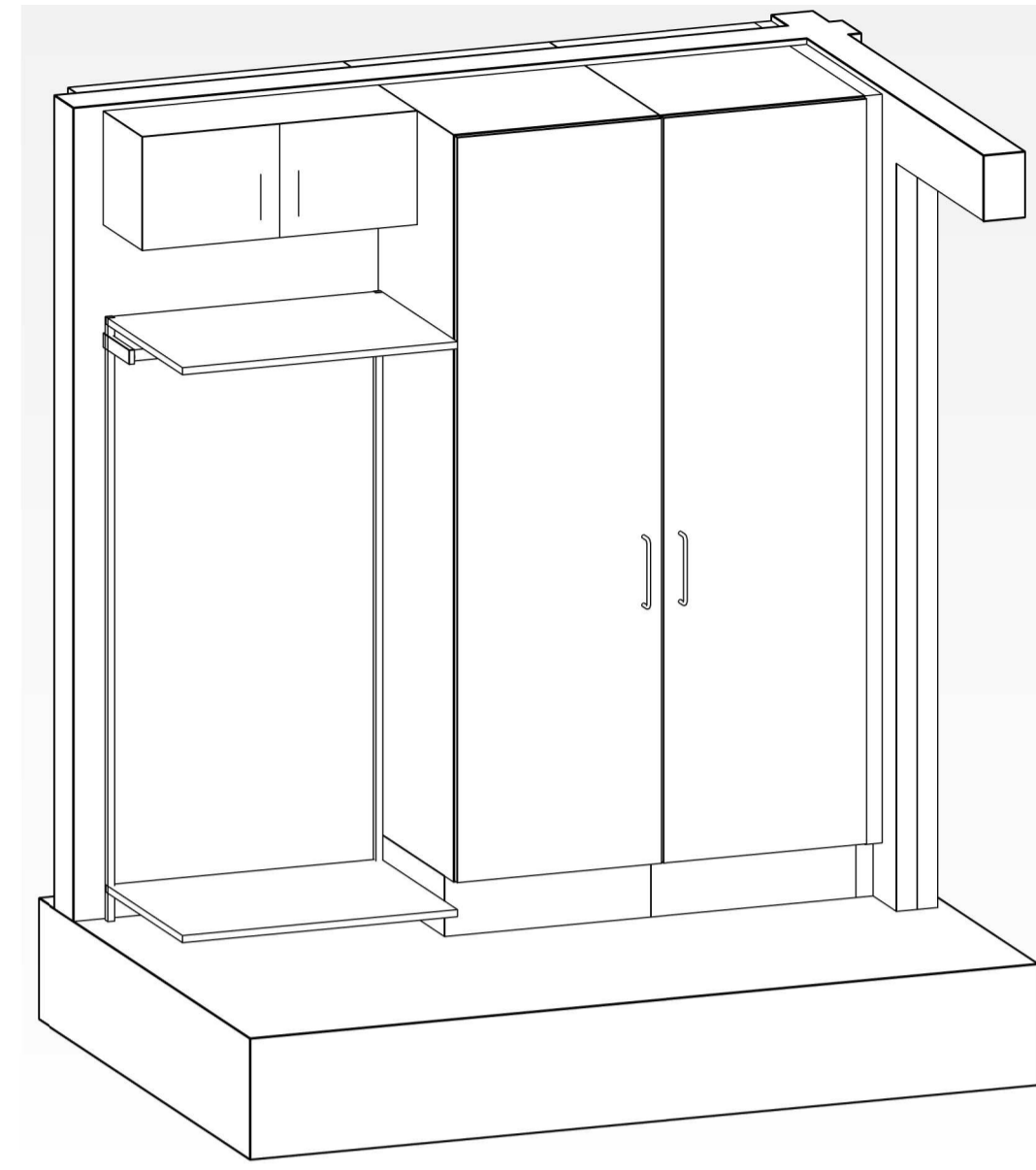

Pentry lgh-3d-2

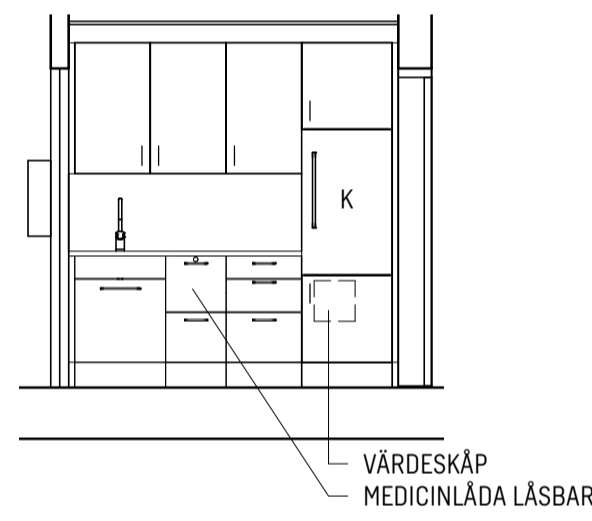

Hall-Pentry lgh - Vy A  
1 : 50

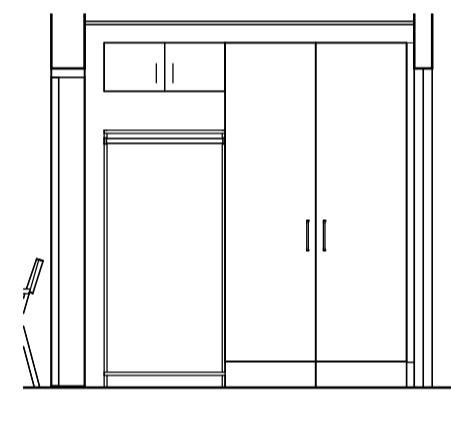

Hall-Pentry lgh - Vy C  
1 : 50

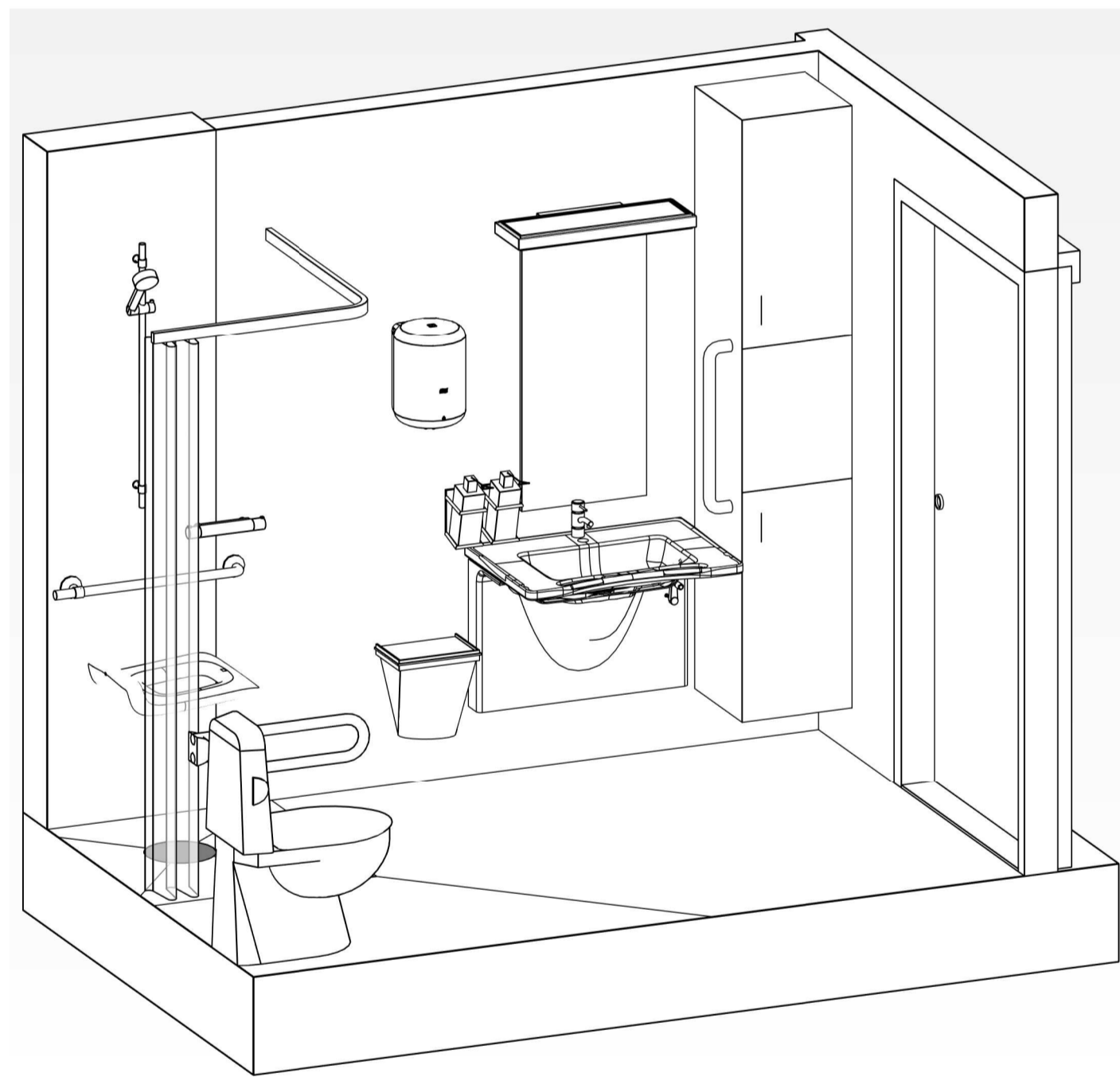

Rwc/d lgh-3d-1

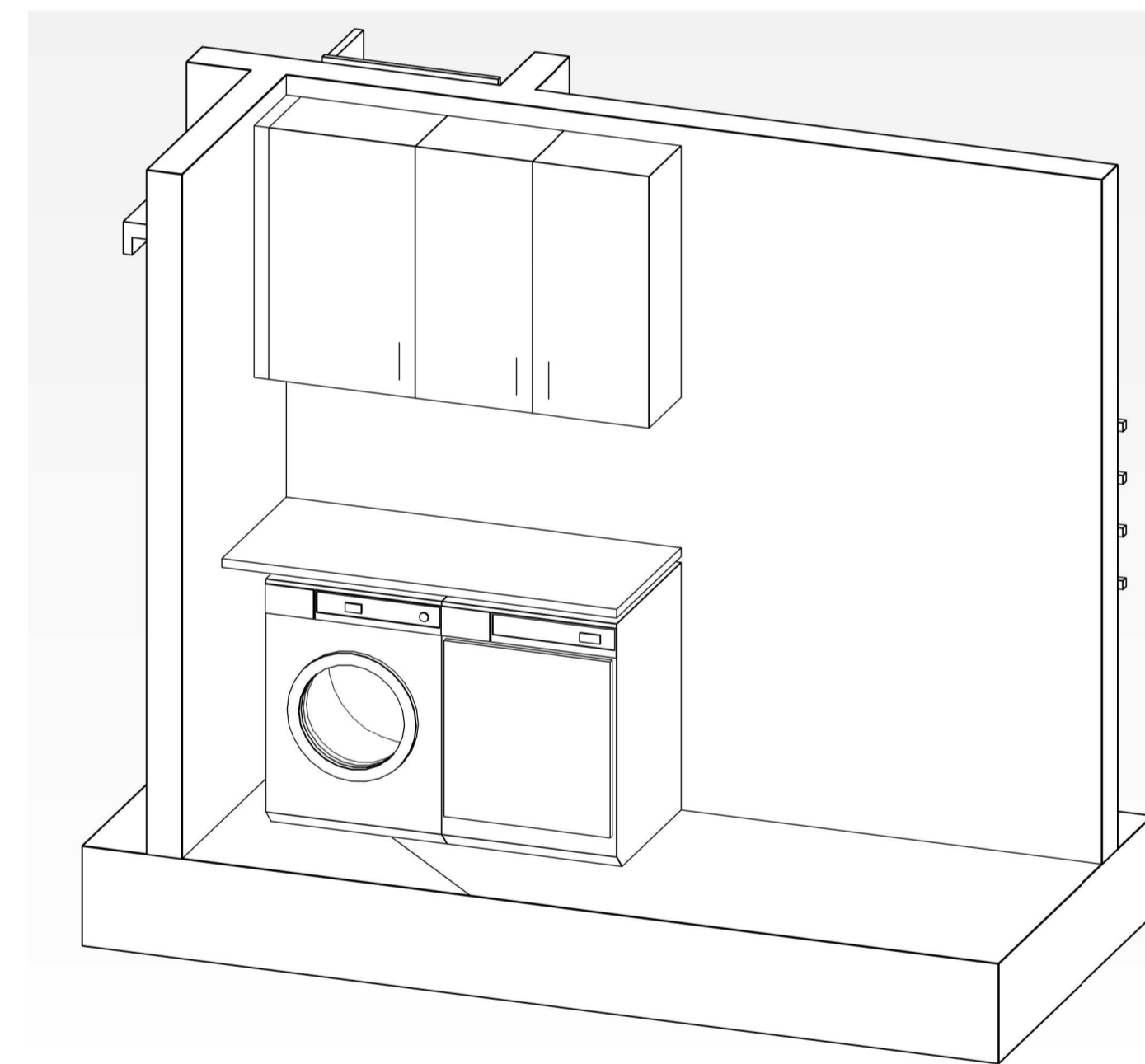

Rwc/d lgh-3d-2

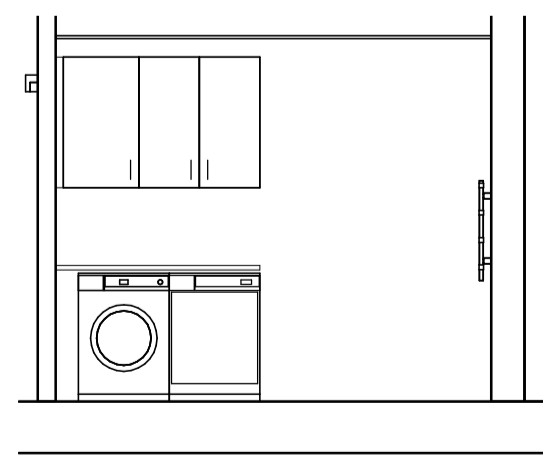

Rwc/d lgh A - Vy A  
1 : 50

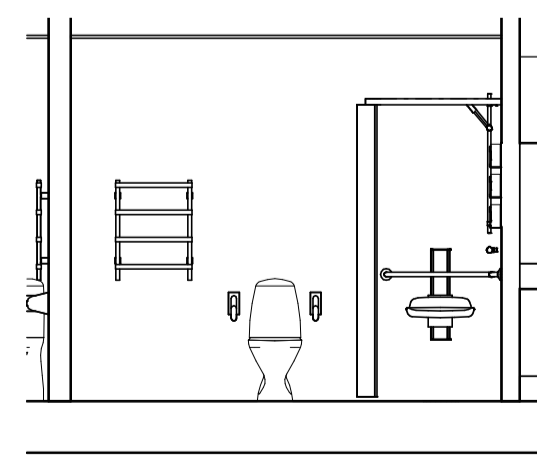

Rwc/d lgh A - Vy B  
1 : 50

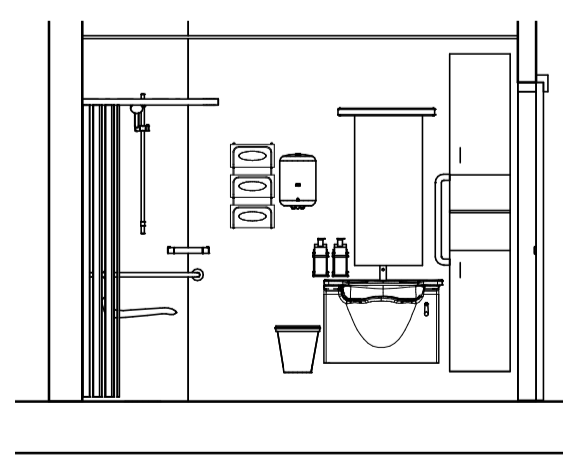

Rwc/d lgh A - Vy C  
1 : 50

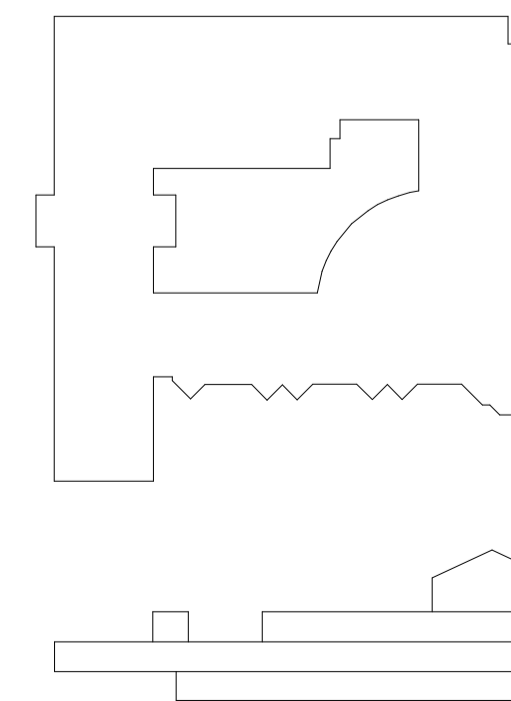
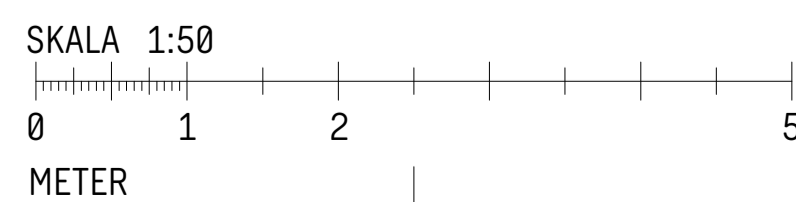

BET	ÄNDRINGEN AVSER	DATUM	SIGN
<b>BYGGHANDLING</b>			
NYBACKEN ÄLDREBOENDE KV. LÄGRET 3, ARVIKA			
ARVIKA FASTIGHETS AB			
KARLSTADS BYGGTJÄNST AB			
A	SWECO ARCHITECTS AB	T: 054-14 17 00	
K	WSP AB	T: 010-722 50 00	
E	ELEKTROTEKNISKA BYRÅN AB	T: 010-788 60 00	
W	TINGVALLASTADENS RÖR AB	T: 054-770 88 70	
V	SWECO SYSTEMS AB	T: 054-14 17 00	
BR	BRANDSKYDDSLAGET AB	T: 054-770 78 00	
M	NRC GROUP AB	T: 08-701 70 17	
UPPDRAG NR	RITADKONSTR AV	UPPDRAGSLEDARE	
11003009-100	SJOK	BOHY	
DATUM	ANSVARIG		
2020-05-18	EVA SVENSSON		
OM- OCH TILLBYGGNAD INREDNING/UPPSTÄLLNING LGH A HALL/PENTRY RWC/D			
SKALA	NUMMER	BET	
A1 = 1:50/1:20 A3 = 1:100/1:40	A-46-4-001		